

This document contains information that is confidential and proprietary to CORIGY, that will not be copied or reprinted or delivered

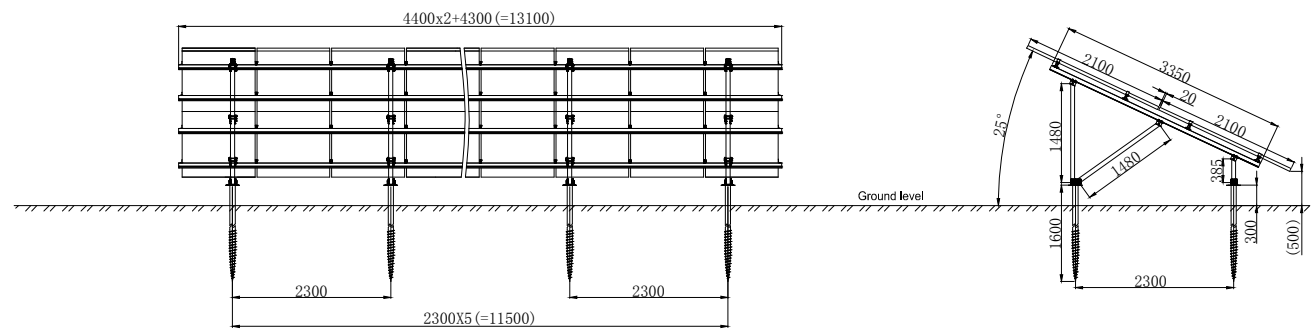
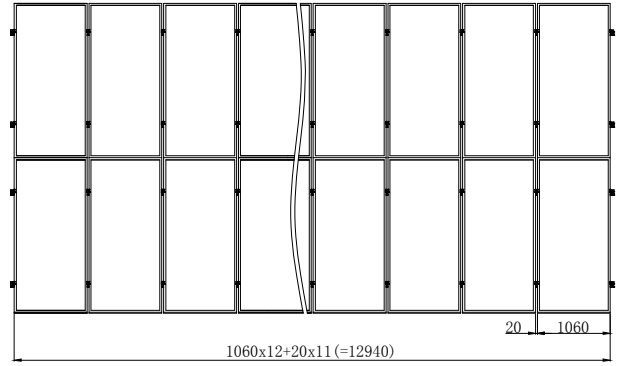
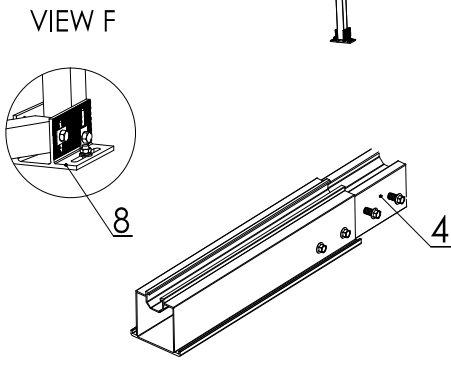
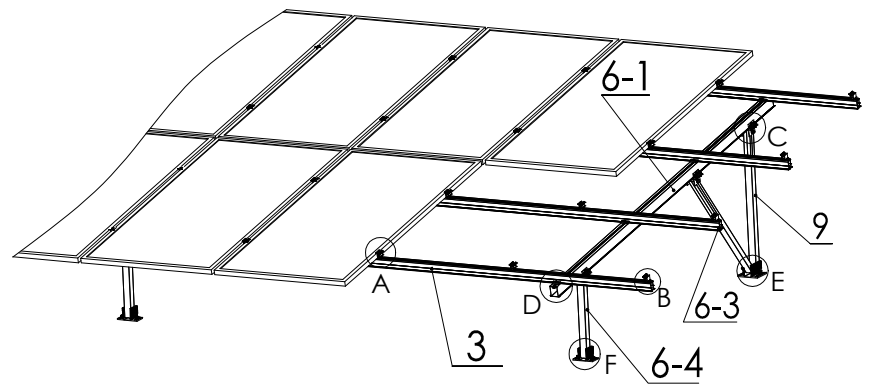
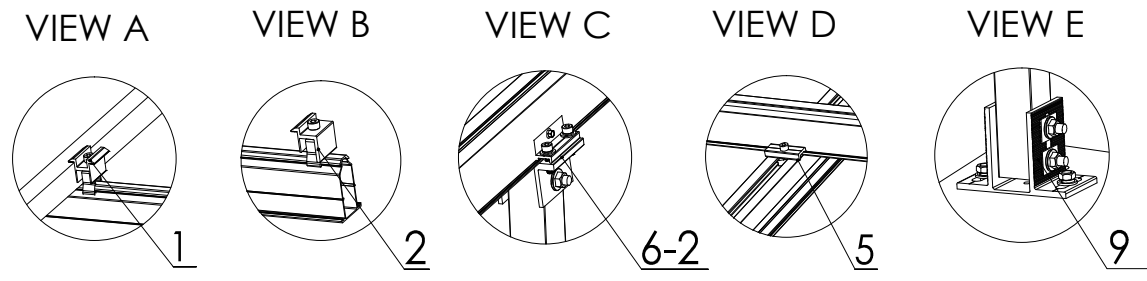

11	CP-RM-4300	CP-Rack, Series M	L=4300	4	
10	CP-GSF-1600	Ground Screw	L=1600	12	
9	CP-KC-LC-01	CP-KC Leg Caps,01		6	
8	CP-KC-LC	CP-KC Leg Caps		6	
7	CP-KC-RL-1480	CP-KC Rear Leg-01	L=1480	6	
6-4	CP-KC-FL-385	CP-KC Front Leg-01	L=385	6	
6-3	CP-KC-LEP-1480	CP-KC Enforcement Pipe	L=1480	6	
6-2	CP-KC-TCL	CP-KC Top Cap for Legs		18	
6-1	CP-RK-3350	CP-Rack, Series K 01	L=3350	6	
6	CP-KC-PAF-335025	CP-KC Pre-assembled Frame		6	
5	CP-RCD	Rail Splice, Series D		48	
4	CP-RS-M-01	Rail Splice M		8	
3	CP-RM-4400	CP-Rack, Series M	L=4400	8	
2	CP-EC-35	Standard End Clamp		8	
1	CP-IC-35	Standard Middle Clamp		44	
No.	Part NO.	Item	Description	QTY	U/N

			Installation Site		Unless other specified, the main dimension unit is mm	
			Wind Load	34 m/s	Drawn by/Date	
			Snow Load	0.9 KN/m ²	Checked/Date	
			Angle	25°	QA./Date	
VER.	Change Mark	DCN NO.	Panel	2100x1060x35	Standard/Date	
Change History			Project information		Approved/Date	

CORIGY 科锐欧(厦门)新能源科技有限公司
 Create Re-Energy xiamen corigy new energy technology CO.,LTD.
 TEL: +86-592-6883200 E-mail: sales@corigy.com

Model Layout	2x12	Drawing NO.	CP-02181317-01
Project	CP-KC All aluminum system Ground Solar Project		DATE 2021-07-19